



Medi-Hook

Plastic IV secondary set bag hanger

The Medi-Hook performs a fundamental yet critical function in IV medication delivery. As a vital accessory for secondary IV medication sets, the Medi-Hook properly positions the primary solution bag to the appropriate height.

Features

- Compact for automated kit assembly
- Robust design
- Folded for easy packaging
- Light weight
- Large hanging loop
- Plastic material

Benefits

- Easily loaded in and out of a magazine for automation systems
- Withstands 20 lb. pull test
- Occupies minimal space in assembled kits
- Contributes minimal weight to finished assembled kit
- Easy to hang
- Can be used in CAT/PET scan units

Its compact and ergonomic design allows for ease of automated kit assembly as well as easy clinical manipulation and set up. Manufactured from light weight, polyethylene material, the Medi-hook contributes minimal weight to packaged kits.

NP Medical's upstream, high volume, fully automated manufacturing capabilities ensure on-time delivery of precise components. All NP Medical products are manufactured in a cleanroom under cGMP guidelines, offering complete manufacturing traceability and meeting ANSI/ISO standards. NP Medical is an ISO 13485 registered manufacturer. ANSI/ISO standards.



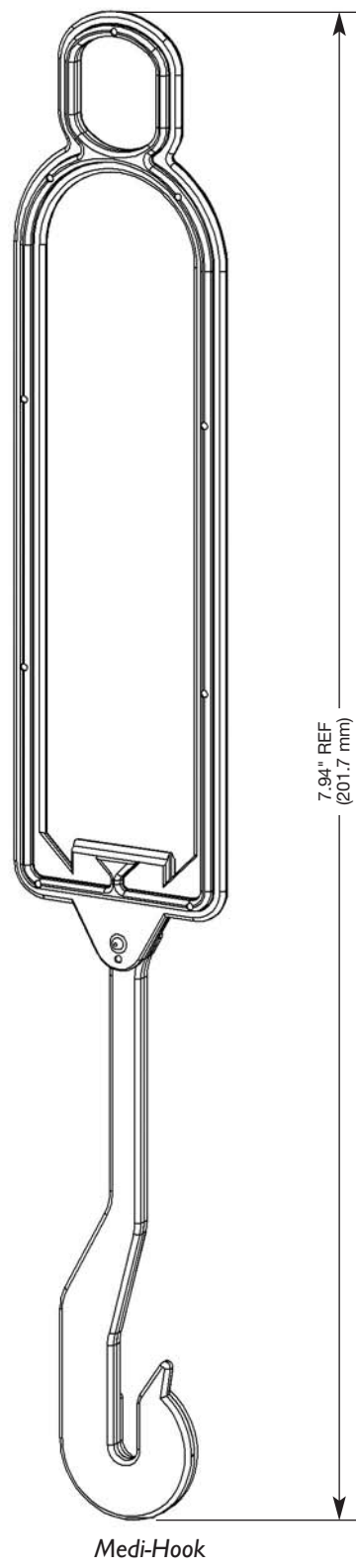
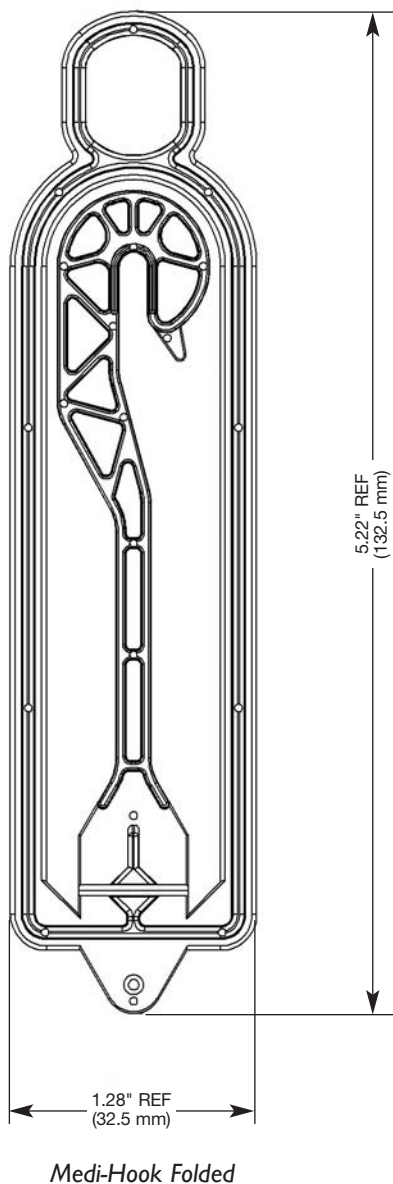

Specifications and ordering information

Part Number

5N02-A300-H

Material

Polyethylene

Pull Test

Withstands 20 lbs.
minimum pull test

Standard Packaging: Bulk, non-sterile, in cases of 2,000 units

ISO 13485
Registered



101 Union Street,
Clinton, MA 01510
www.npmedical.com
Customer Service Telephone:
(978) 365-2500
Fax: (978) 365-4025
Email: sales@npmedical.com